

PARTS MANUAL

FOR

DP

DOUBLE END

TENONER

BED ASSEMBLY.

Ref. No.	Part No.	No. Off	Description
1-02220	1079/248	1	Cover plate.
2-02143	1079/1645	1	Terminal Box.
3-02266	1079/1081	1	Base for fixed column.
4-02257	1079/345	1	Bed.
5		1	Vitaliser unit.
6-02254	1079/260	1	Feed gearbox tie (R.H.).
7-02277	1079/V/1641	1	Adjustable auxiliary support bracket
8-02642	1079/V/684	1	Auxiliary bed.
9-02272	1079/V/1642	1	Fixed auxiliary support bracket.

www.wadkin.com
 info@wadkin.com

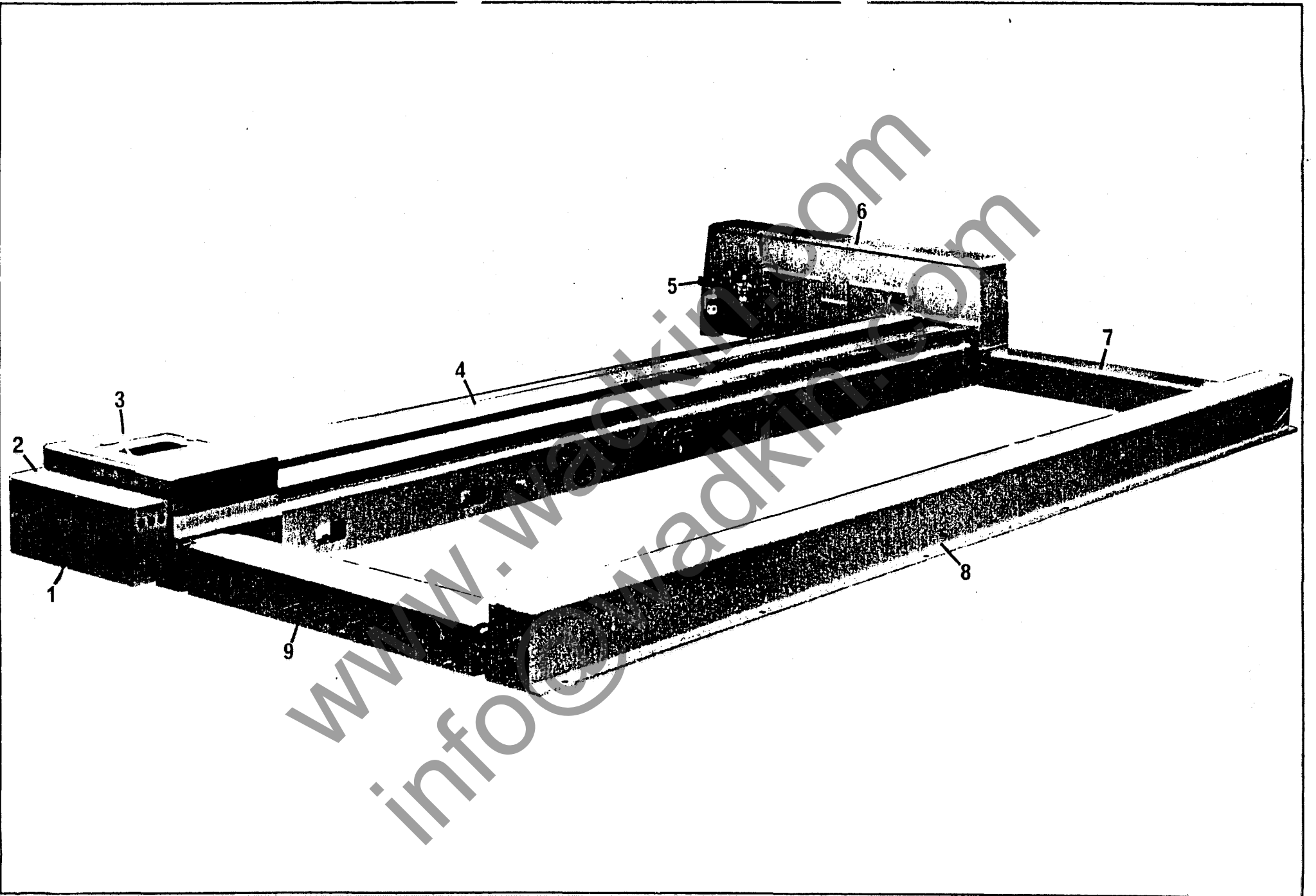

COLUMN ASSEMBLY

Ref. No.	Part No.	No. Off	Description
20	1079/57	1	Main column.
21	1079/499	1	Gib strip.
22	1079/1716	1	Top pressure screw.
23		1	Top pressure counter (ROTATION 1).
24	1079/1105	1	Collar.
		1	5 mm dia x 34 long groverlock dowel.
25	51104	2	Bearing.
26	1079/294	1	Collar.
27	1079/1636	1	Rise and fall nut.
28		1	M10 x 45 long stud.
29		1	M10 tap Bristol locking handle.
30		4	1/2" brass washer.
31	1079/141	4	12mm washer.
32		2	M8 x 30 long hexagon head bolt.
		2	M8 locknut.
33		2	M8 x 40 long hexagon head bolt.
		2	M8 locknut.
34	1079/555	2	Rear stop for top pressure bracket.
35		2	M12 aerotight nut.
36		2	M12 x 50 long stud.
37		4	M12 x 25 long socket grubscrew.
38		1	8 mm washer.
39		1	M8 x 25 long socket capscrew.
40	1079/1295	1	Left hand top pressure slide.
	1079/271	1	Right hand top pressure slide.
41	1079/387	2	Top pressure stud.
42	1079/778	2	Washer.
43		2	M16 spring washer.
44	1079/388	2	Top pressure nut.



DRIVE SPROCKET ASSEMBLY.

Ref. No.	Part No.	No. Off	Description
50	1079/925	1	Right hand, 72 pitch chain beam.
	1079/1289	1	Left hand, 72 pitch chain beam.
	1079/1104	1	Right hand, 80 pitch chain beam.
	1079/1292	1	Left hand, 80 pitch chain beam.
51	1079/803	1	Guide rod for 72 pitch chain beam.
	1079/424	2	Guide rod for 80 pitch chain beam.
52			M4 x 20 long socket capscrew (state quantity required).
53	1079/1255	1	Right hand inner return guide, 72 pitch chain beam.
	1079/1112	1	Left hand inner return guide, 72 pitch chain beam.
	1079/1211	2	Right hand inner return guide, 80 pitch chain beam.
	1079/1107	2	Left hand inner return guide, 80 pitch chain beam.
54		1	M8 x 20 long hexagon head bolt.
		1	M8 locknut.
55	1079/325	2	Cordial action bracket.
56	1079/326	2	Cordial action guide.
57		4	8mm washer.
58		4	M8 x 20 long hexagon head bolt.
59			M4 x 10 long countersunk screw (state quantity required).
60	1079/1145	2	Return guide for 72 pitch beam.
	1079/1142	4	Return guide for 80 pitch beam.
61	1079/1256	1	Right hand outer return guide, 72 pitch chain beam.
	1079/1113	1	Left hand outer return guide, 72 pitch chain beam.
	1079/1210	2	Right hand outer return guide, 80 pitch chain beam.
	1079/1106	2	Left hand outer return guide, 80 pitch chain beam.
62			M6 x 10 long countersunk socket screw (state quantity required).
63	1079/848	1	Clamp ring.
64		3	M10 x 30 long socket capscrew.
65	1079/66	1	Drive sprocket.
66	1079/147	1	Jacking boss.
67		1	M8 x 16 long socket capscrew.
68		2	M10 x 20 long socket grubscrew.
69	1079/854	1	Feed chain driving hub.
70	SKF-6019-ZS	2	Bearing.
71	1079/145	1	Locking ring.
72	RM-1045/30	2	"O" ring.
73	1079/144	1	Spacer.
74	1079/846	1	Drive gear.
75		1	10 x 8 x 25 long feather key.
76	MB-19	1	Tab washer.
77	1079/847	1	Notched nut.
78	1026/396	2	Washer for main drive shaft bracket.
79		1	M10 x 25 long hexagon head bolt.
80	1079/1008	4	Washer for main drive shaft bracket.
81		2	M10 x 40 long socket capscrew.
82	1079/842	1	Right hand bracket for main drive shaft.
	1079/843	1	Left hand bracket for main drive shaft.
83		2	M10 x 65 long socket capscrew.

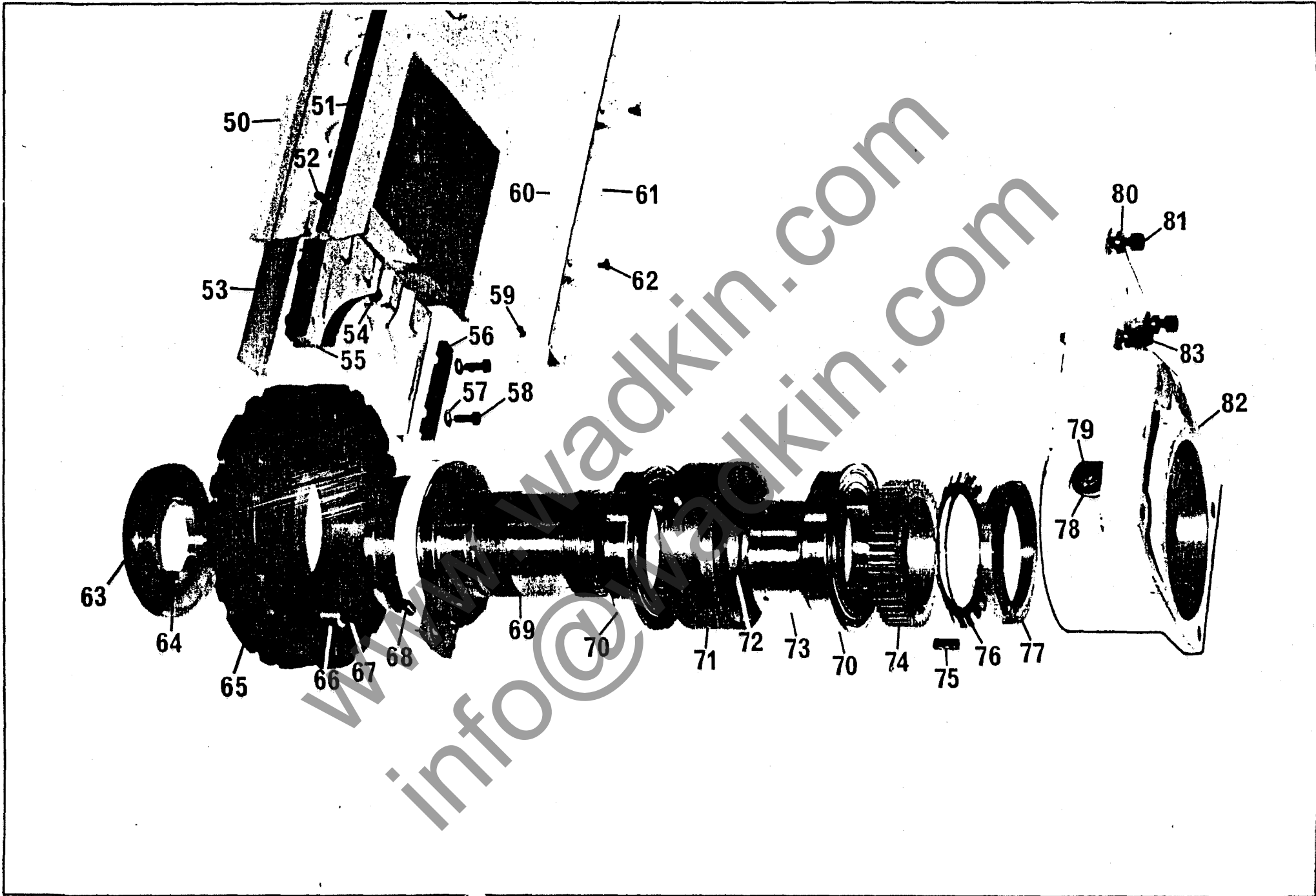

IDLE SPRCKET ASSEMBLY

Ref. No.	Part No.	No. Off	Description
90	1079/15	1	Spindle.
91	1079/310	2	Idle sprocket.
92	SKF-6008-2RS	2	Bearing.
93	1079/356	2	Front cordial action guide.
94		4	M6 locknut.
95	1079/200	1	Front idle sprocket.
96		4	8mm washer.
97		4	M8 x 22 long hexagon head bolt.
98	1079/16	1	Idle sprocket locking cap.
99		1	M12 x 30 long nylok socket capscrew.
100	1079/1256	1	Right hand outer return guide, 72 pitch chain beam.
	1079/1113	1	Left hand outer return guide, 72 pitch chain beam.
	1079/1210	2	Right hand outer return guide, 80 pitch chain beam.
	1079/1106	2	Left hand outer return guide, 80 pitch chain beam.
101			M4 x 20 long socket capscrew (state quantity required).
102	1079/803	1	Guide rod for 72 pitch chain beam.
	1079/424	2	Guide rod for 80 pitch chain beam.
103	1079/314	1	Tension boss.
104		2	M16 locknut.
105		6	Belville washer.
106	1079/216	1	Fibre washer for spring jockey arm.
107	1079/313	1	M16 stud.
108		1	M16 x 12 long button head socket screw.
109	1079/833	2	Brush for track.
110			M4 x 10 long countersunk screw (state quantity required).
111	1079/1145	2	Return guide for 72 pitch beam.
	1079/1142	4	Return guide for 80 pitch beam.
112	1079/792	1	Oil brush adaptor.
113		2	M6 x 10 long countersunk socket screw.
114	C-61751	1	Nylon brush for chain track.
115	1079/1255	1	Right hand inner return guide, 72 pitch chain beam.
	1079/1112	1	Left hand inner return guide, 72 pitch chain beam.
	1079/1211	2	Right hand inner return guide, 80 pitch chain beam.
	1079/1107	2	Left hand inner return guide, 80 pitch chain beam.
116			M6 x 10 long countersunk socket screw (state quantity required).

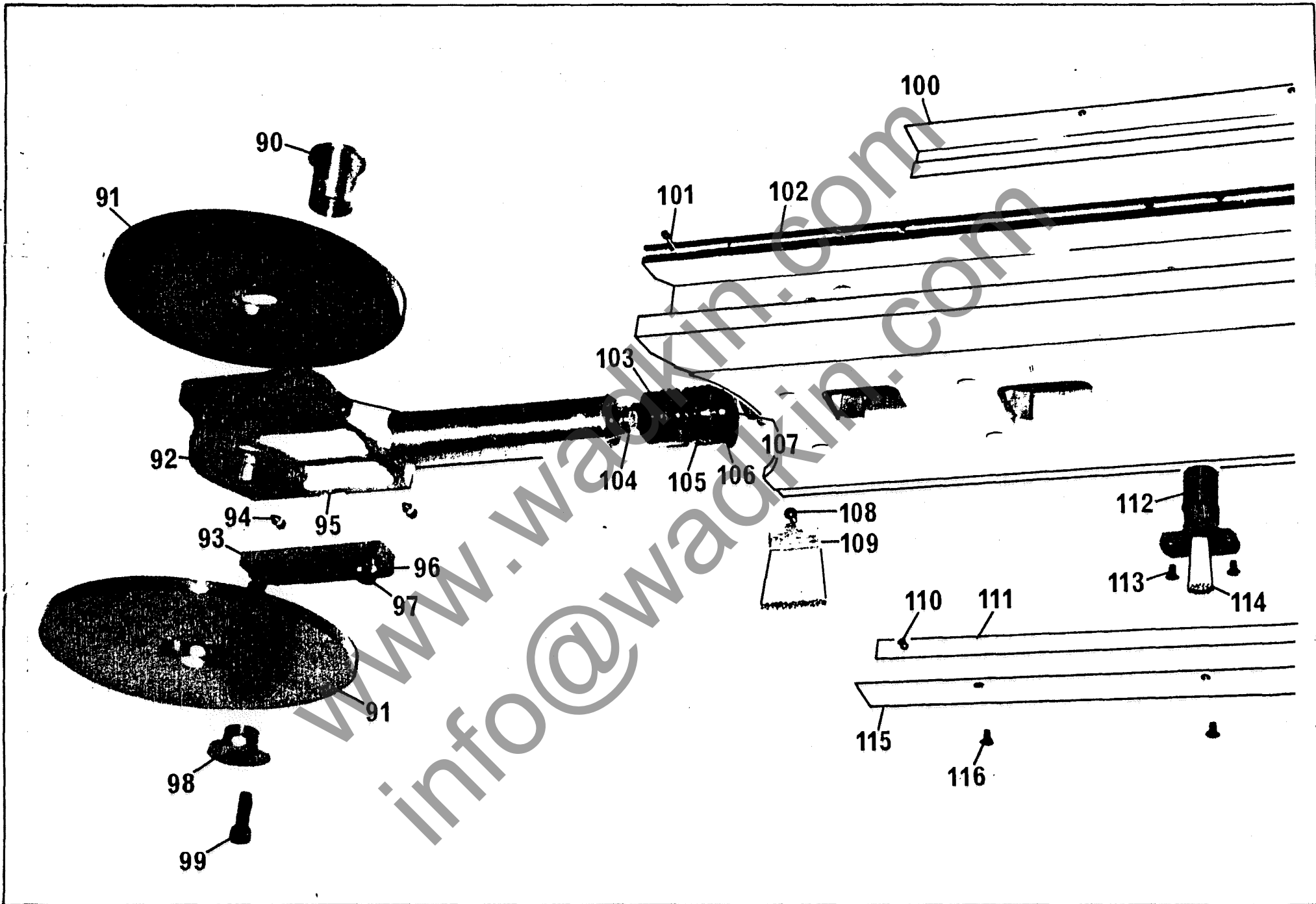

TOP PRESSURE DRIVE HOUSING ASSEMBLY.

Ref. No.	Part No.	No. Off	Description
125		1	M6 x 12 long button head socket screw.
126	1073/136	1	Washer
127	1079/137	1	Top pressure drive locknut (state R.H. or L.H. thread).
128	1079/136	1	Top pressure drive adjusting nut (state R.H. or L.H. thread).
129	1079/67	1	Cover for top pressure feed housing.
130	ZKL51105	1	Thrust bearing
131		6	50 x 25.4 x 1.5 Belleville washer.
132	SKF62052RS	4	Bearing
133	1097/107	1	Top drive shaft for pressure (state R.H. or L.H. thread).
134	1079/110	1	Clutch plate.
135	1079/108	1	Ferodo clutch pad.
136		1	25 1/D x 30 O/D x 35 long oilite bush.
137	1079/109	1	Clutch sprocket.
138	INA-AKK-2542		
	AS 2542	1	Thrust bearing.
139	NO. 26	1	Connecting link.
140	110-056	1	Chain.
141	1079/64	1	Top pressure feed housing.
142	1079/138	1	Dust cap.
143		3	M5 x 16 long countersunk socket screw.
144		1	M10 locknut.
145	1079/98	1	Driven gear for top pressure.
146	1069/190	2	Washer.
147		2	M10 x 30 long hexagon head bolt.
148		3	7 x 8 x 30 long feather key.
149	1079/269	1	Idle sprocket spindle.
150		1	12 1/D x 16 O/D x 16 long oilite bush.
151		1	M6 x 40 long hexagon head bolt.
152	1079/270	1	Link for chain tension adjustment.
153		1	M10 x 30 long socket capscrew.
154	1079/268	1	Idle sprocket.
155		1	M5 x 20 long groverlock dowel.
156	1079/106	1	Sprocket for lower drive shaft.
157	1079/104	1	Top pressure lower drive shaft.
158		6	M8 x 25 long socket capscrew.

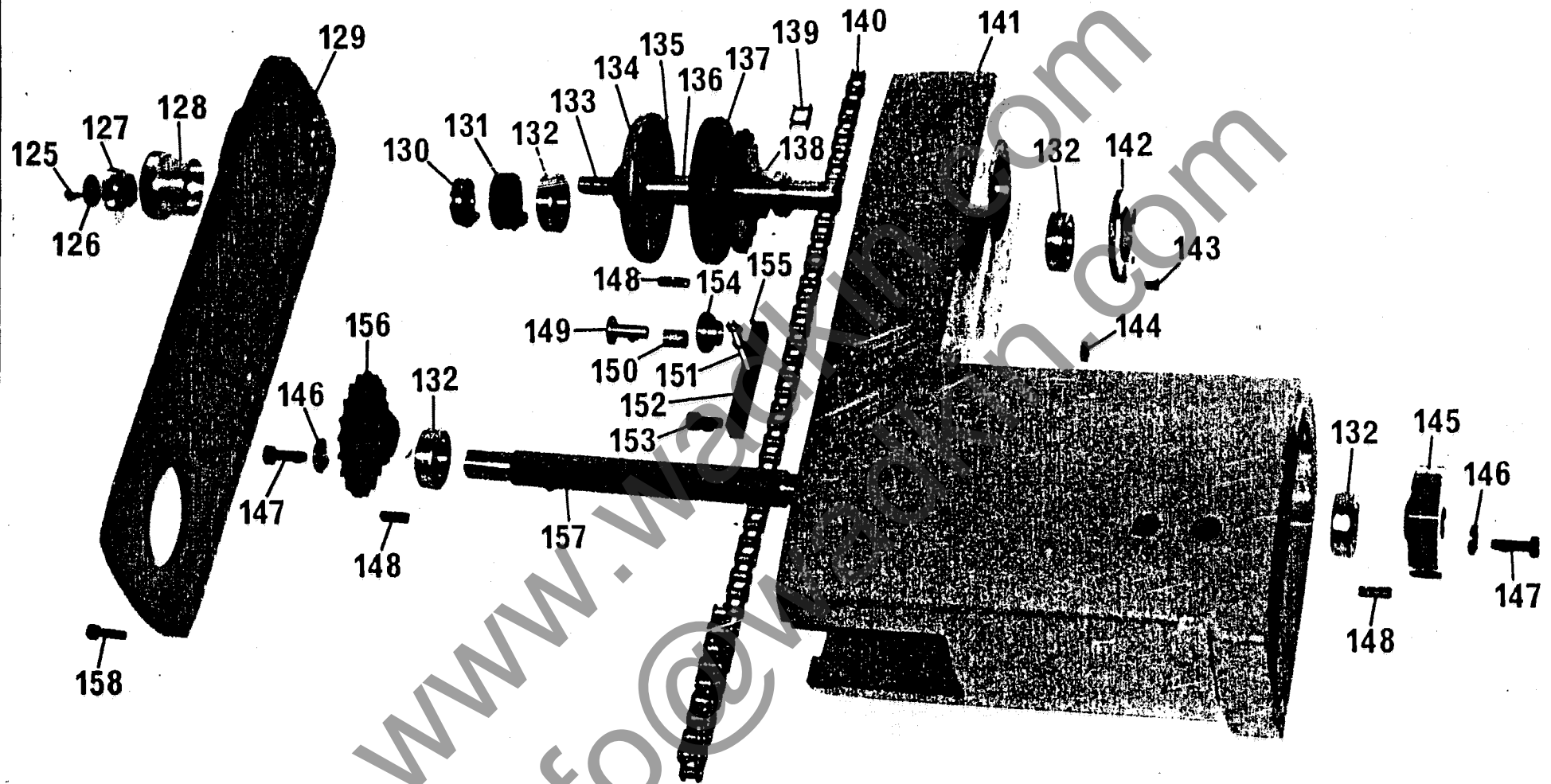

TOP PRESSURE ASSEMBLY.

Ref. No.	Part No.	No. Off	Description
170		4	M8 x 20 long countersunk socket screw.
171	1079/697	1	Top pressure drive shaft.
172	7000-062	4	Internal circlip.
173	6007/EE	2	Bearing.
174	1079/651	2	Top pressure drive pulley. <i>DP 613</i>
175	1079/654	4	Top pressure rear pivot spacer.
176	1079/655	4	Top pressure rear pivot stud. <i>DP 612</i>
177		1	M8 x 16 long socket grubscrew.
178		1	8 x 7 x 20 long feather key.
179	K26/35	4	Kabel wrap tie.
180	R14	2	Motorgear cover.
181	1079/657	1	Top pressure rear pivot locknut.
182	1079/661	1	Top pressure drive coupling. <i>DP 615</i>
183		4	8 mm washer.
		4	M8 aerotight nut.
184	1079/312	2	Universal joint type DS14.
185	1079/134	1	Top pressure drive shaft.
186		1	7 x 8 x 50 long feather key.
187	1079/135	1	Top pressure drive collar.
188	1079/244	1	Shaft for top pressure drive sprocket.
189		4	10 mm dia x 45 long spiral pin.
190	1079/709	1	Top pressure adjusting nut.
191	1079/708	1	Top pressure adjusting stud.
192	1079/656	2	Top pressure rear pivot washer.
193	1079/658	1	Top pressure rear pivot shaft. <i>DP 614</i>
194	1079/649	1	Rear pivot arm.
195		1	M8 locknut.
196		1	M8 x 40 long hexagon head bolt.
197		1	1/4" BSF straight grease nipple.
198	1079/951	1	Pivot bearing collar.
199		1	M6 x 6 long socket grubscrew.
200	1079/952	1	Top pressure pivot pin.

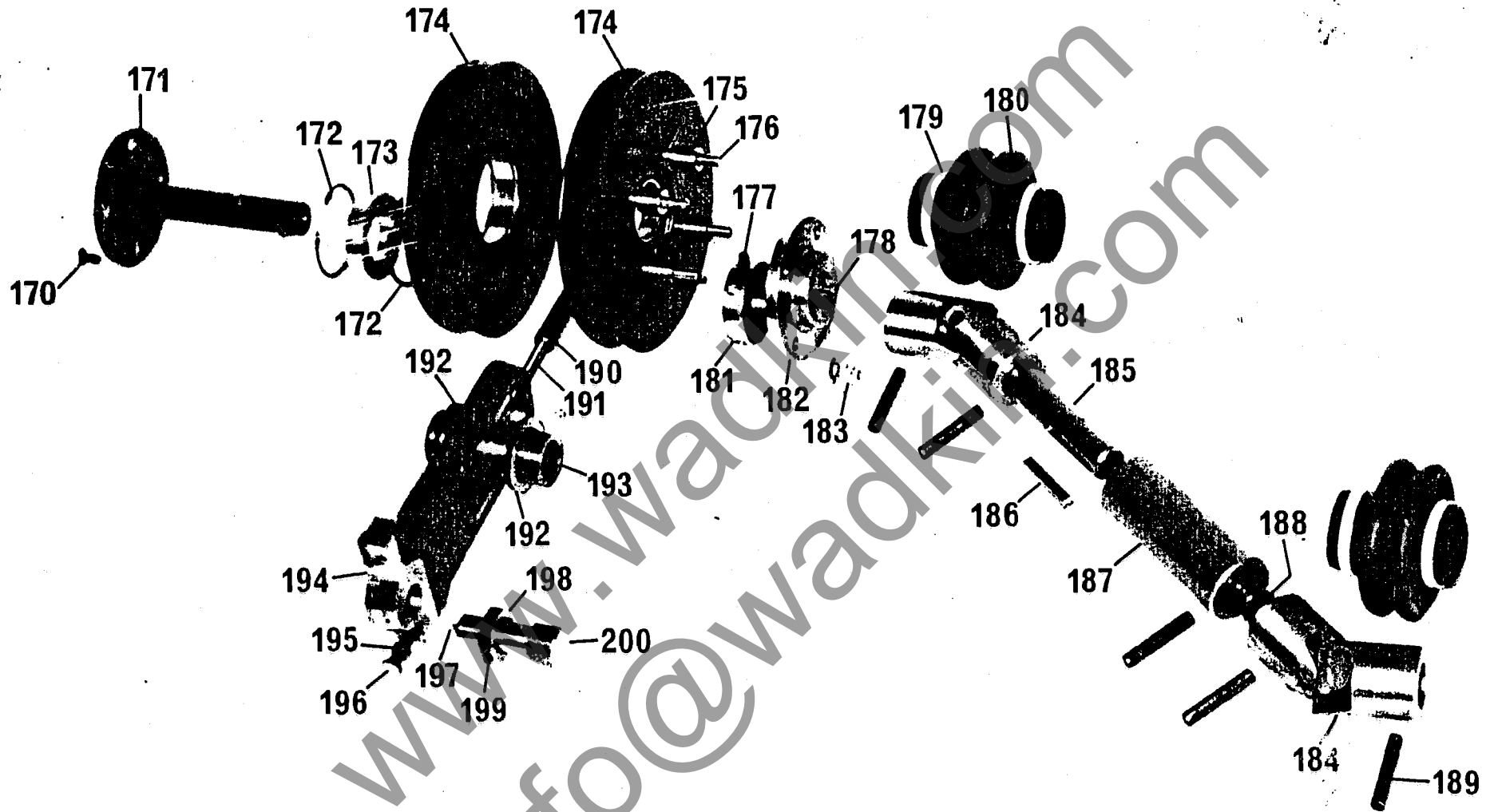

TOP PRESSURE PULLEY ASSEMBLY.

Ref. No.	Part No.	No. Off	Description
210	1079/662	2	Top pressure pulley. DP 616
211	1079/952	1	Top pressure pivot pin.
212		1	M6 x 6 long socket grubscrew.
213	1079/951	1	Pivot bearing collar
214		1	M8 x 40 long hexagon head bolt.
		1	M8 locknut.
215	1079/650	1	Front pivot arm.
216		1	1/4" BSF straight grease nipple.
217		1	M8 x 10 long socket head grubscrew.
218	1079/659	1	Top pressure front pivot shaft. DP 620
219	7000-062	4	Internal circlip.
220	6007-EE	2	Bearing.
221	1079/660	2	Top pressure front pivot washer.
222		2	M8 x 20 long countersunk socket screw.

www.wadkin.com
 info@wadkin.com

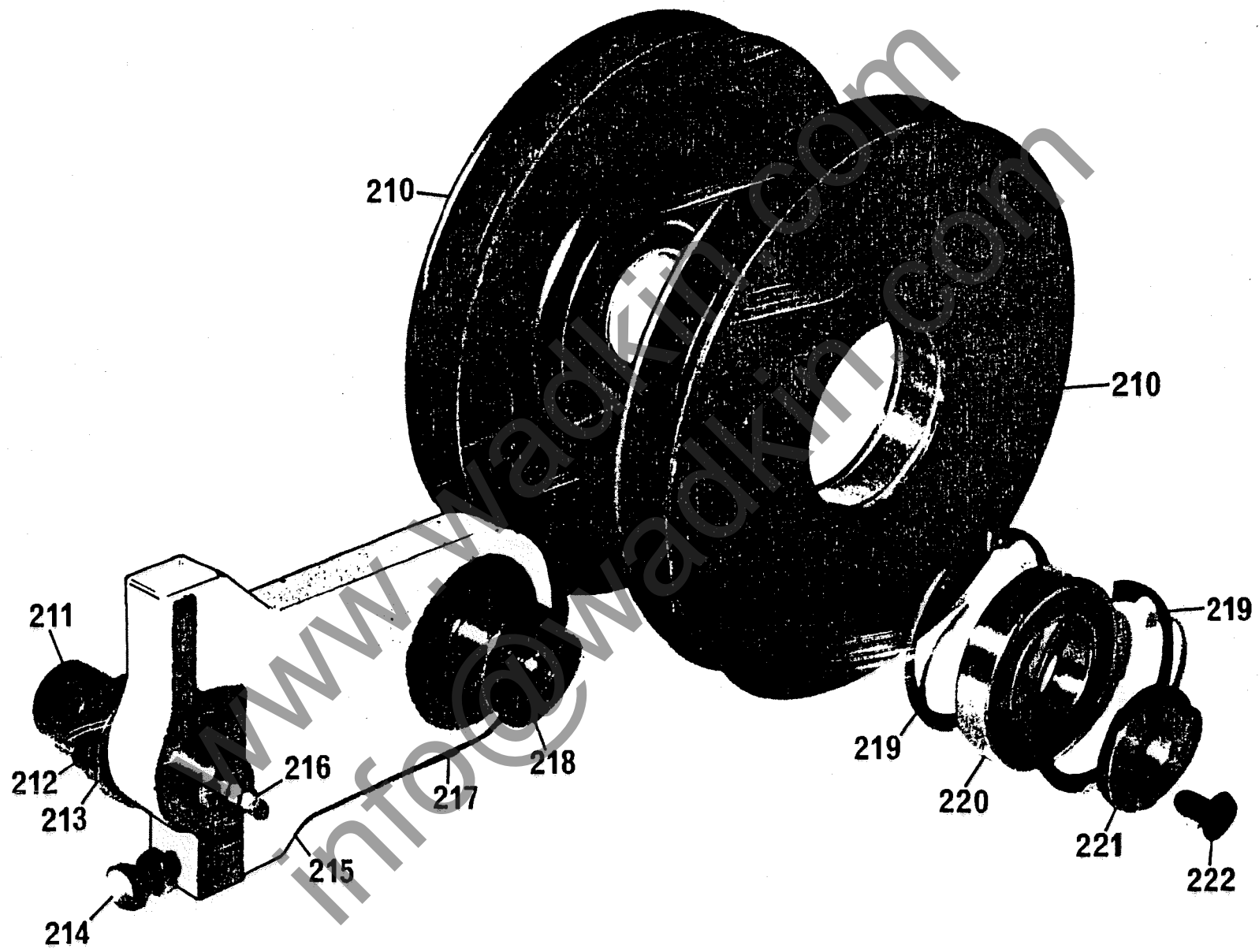

PRESSURE ROLLER ASSEMBLY.

Ref. No.	Part No.	No. Off	Description
230	7100-012		External circlip (state quantity required).
231	1079/1007		Washer for top pressure roller (state quantity required).
232	1079/674		Top pressure roller (state quantity required).
233	1079/653		Top pressure roller spindle (state quantity required).
234			M5 x 8 long nylok socket grubscrew (state quantity required).
235			M8 x 20 long socket grubscrew (state quantity required).
236	1079/652		Top pressure roller shaft (state quantity required).
237	ETS 154		Compression spring (state quantity required).
238	1079/707		Front top pressure roller shaft (state quantity required).

www.wadkin.com
info@wadkin.com

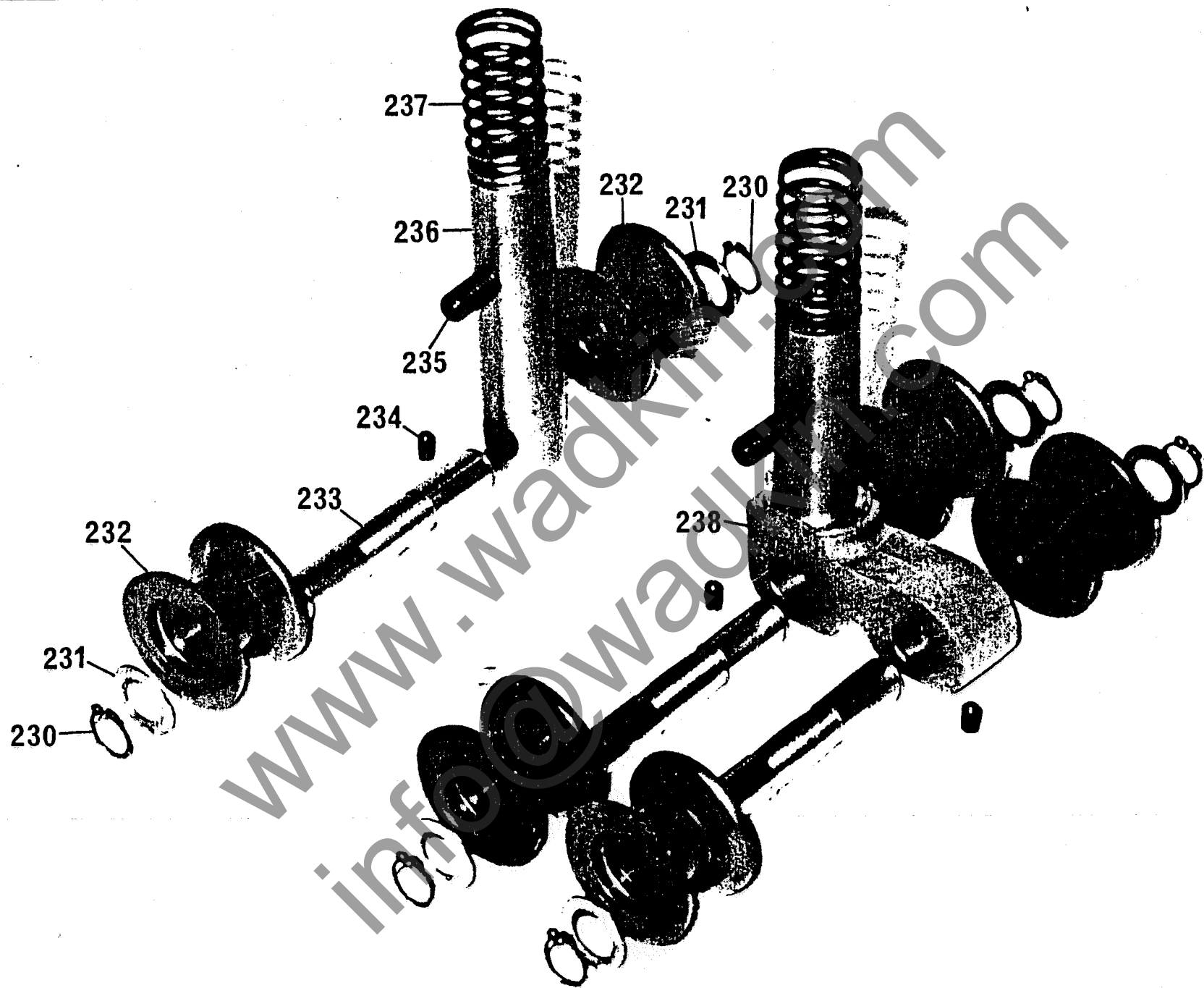

TOP PRESSURE ASSEMBLY..

Ref. No.	Part No.	No. Off	Description
240	3B2	1	Micro switch for top pressure.
241	1079/669	1	Top pressure pulley guide bar.
242	KO5-22-915	1	Plastic bush.
243	1079/670	1	Top pressure spring seating.
244	ETS-157	1	Compression spring.
245	1069/106	1	Top pressure spring seating.
246	1079/671	1	Top pressure guide locknut.
		1	M5 x 5 long socket grubscrew.
247	1079/1422	1	Top pressure beam (R.H.).
	1079/1421	1	Top pressure beam (L.H.).
248	C-5550	2	Top pressure belt.

www.wadkin.com
 info@wadkin.com

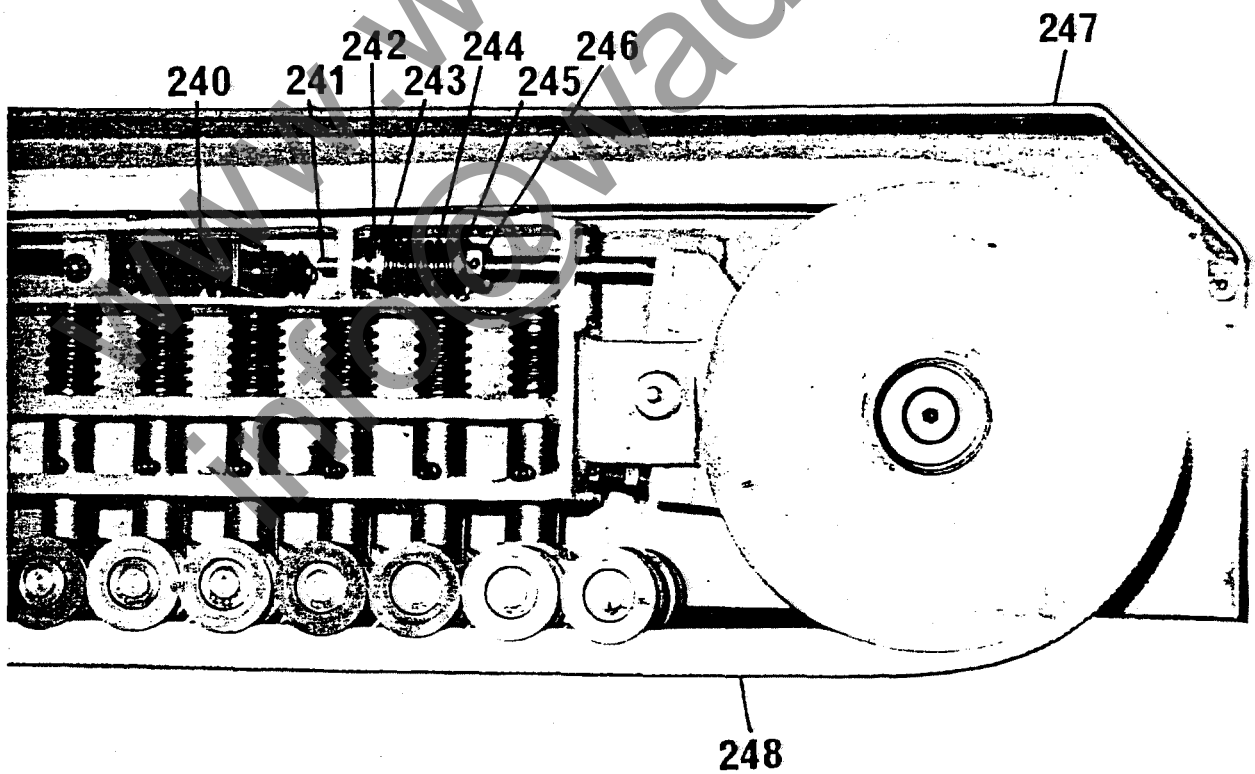
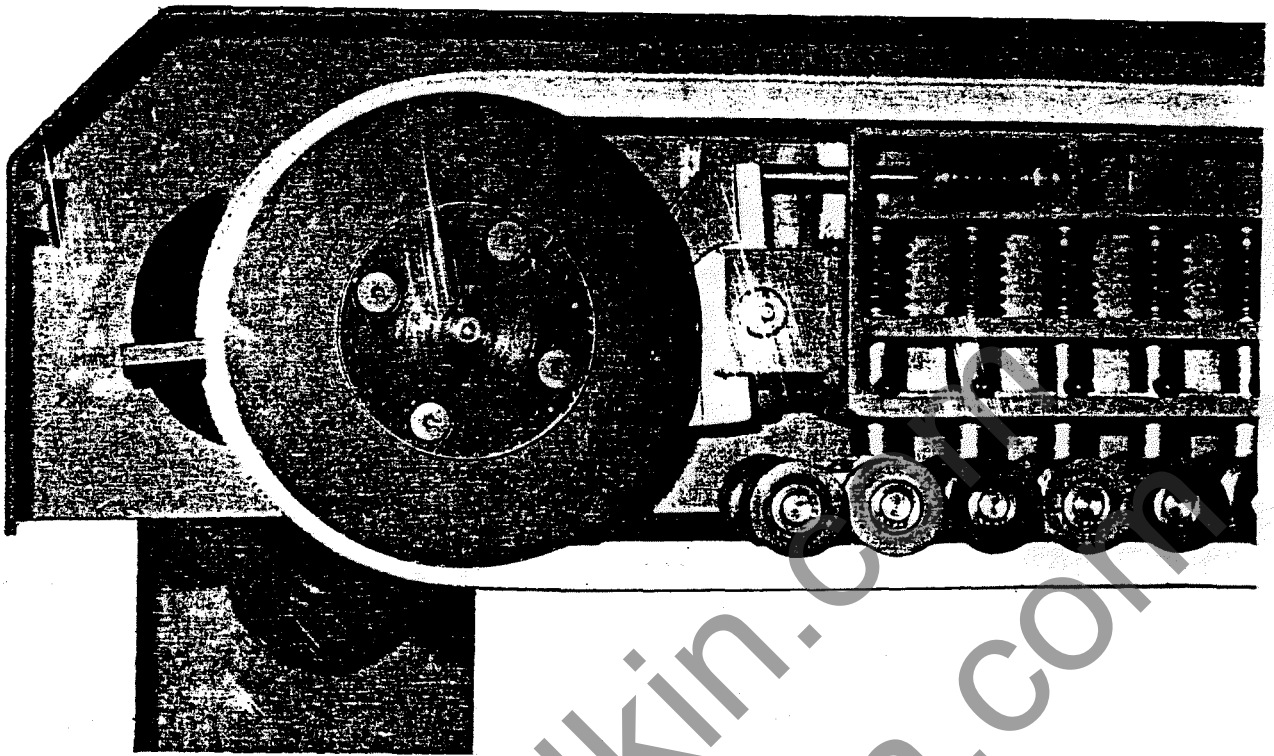

CHAIN LINK ASSEMBLY.

Ref. No.	Part No.	No. Off	Description
250	1079/1		Top pad (state quantity required).
251	1079/1885		Plug for pad (state quantity required).
252			M8 x 20 long button head socket screw (state quantity required).
253	1079/400		Fixed disappearing dog (state quantity required).
254			6 mm dia ball bearing (state quantity required).
	1079/233		Spring seating for disappearing dog (state quantity required).
	ETS / 90		Compression spring (state quantity required).
255	1079/190		Plug for disappearing dog (state quantity required).
256			M6 x 16 long nylok socket screw (state quantity required).
257	1079/1703		Chain axle (state quantity required).
258			6 mm dia x 32 long groverlok dowel (state quantity required).
259	No. 2016		Needle roller bearing (state quantity required).
260	1079/1806		Link (state quantity required).
261	LP - 70		Sealing washer (state quantity required).
262	1079/606		M6 x 15 long socket head capscrew (state quantity required).
263	1079/402		Head for adjustable disappearing dog (state quantity required).
264	1079/401		Body for adjustable disappearing dog (state quantity required)-

www.wa...
info@wa...

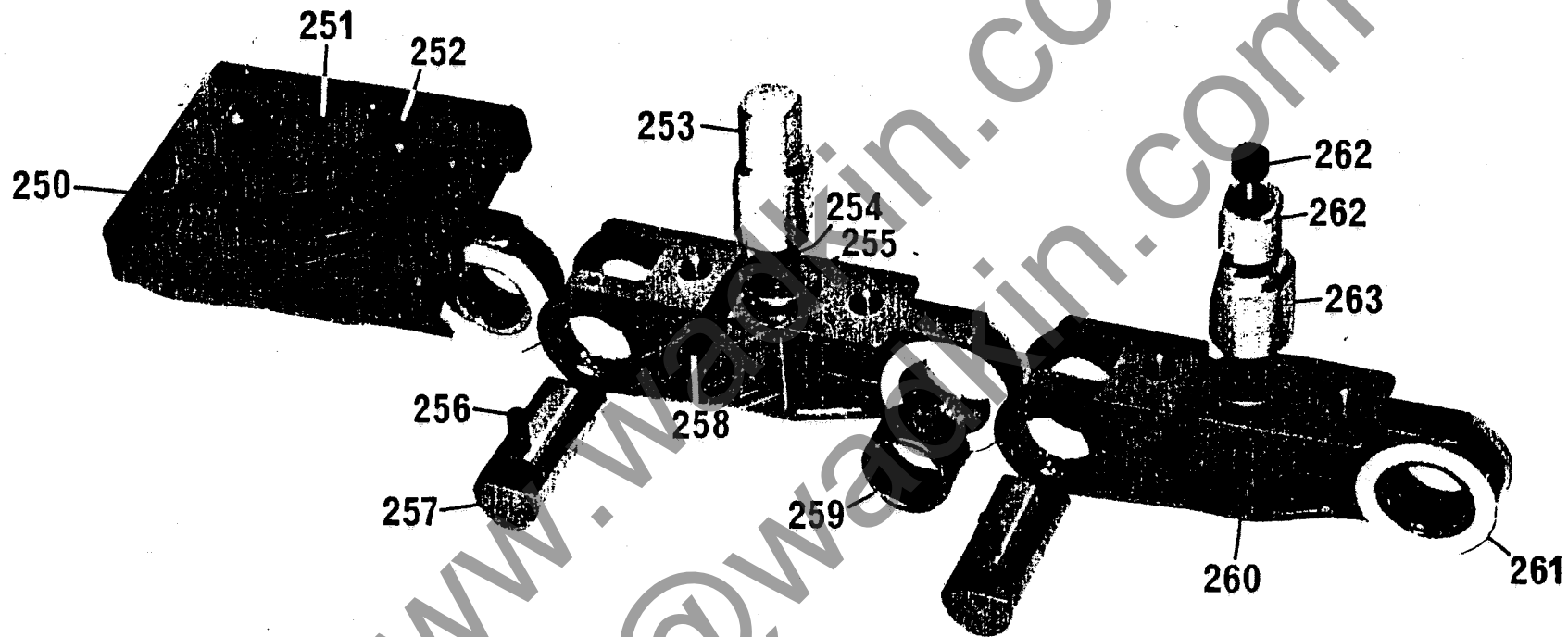

SADDLE ASSEMBLY, TOP VIEW.

Ref. No.	Part No.	No. Off	Description
280		8	M8 x 16 long button head socket screw.
281	1079/333	2	Cover plate for dummy oil reservoir.
282		4	M10 x 16 long button head socket screw.
283	1079/370	1	Cover plate for traverse screw access.
284	1079/276	1	Adjustable saddle.
285	D/S/286	1	Traverse handwheel.
286		1	M6 x 25 long socket capscrew.
		1	M6 nut.
287		1	Traverse motor.
288		4	M10 x 20 long hexagon head bolt.
289	1079/142	1	Locking collar for wormshaft.
290		1	M8 x 25 long socket capscrew.
291	1079/141	1	Locknut for wormshaft.
292		2	M6 x 12 long button head socket screw.
293	1079/983	1	Worm box cover.
294	1079/529	1	Dipstick for wormbox.
295		4	M10 x 25 long socket capscrew.
296		1	M5 x 10 long countersunk socket screw.
297		3	M5 x 12 long countersunk socket screw.
298	1079/1310	1	Bush for traverse handwheel.
299	1079/339	1	Dust cap for traverse gearbox.
300	SKF-6004-2RS	1	Bearing.
301	1079/76	1	Wormshaft for traverse.
302	1079/74	1	Wormbox for traverse.
303	DN/209	2	Bearing.
304	1079/1647	1	Wormwheel for traverse.
305	RM-0795-30	2	"O" ring.
306		8	M8 x 25 long countersunk socket screw.
307		8	M6 x 12 long socket grubscrew.
308	1079/1043	1	Adaptor for wormwheel.
309	1079/1044	1	Pulley adaptor for wormwheel.
310	1079/1687	1	Bottom pulley for end coder.
311	1079/1646	1	End cap for wormbox (pulley end).
	1079/291	1	end cap for wormbox (opposite pulley end).
312		2	M5 x 6 long socket grubscrew.
313	270L050	1	Timing belt.
314		1	End coder.
315		3	M6 x 35 long socket capscrew.
316	SKF-6206-2RS	1	Bearing.
317	7100-020	1	External circlip.
318	M20/42/7	1	Oil seal.
319		2	M6 x 10 long socket capscrew.

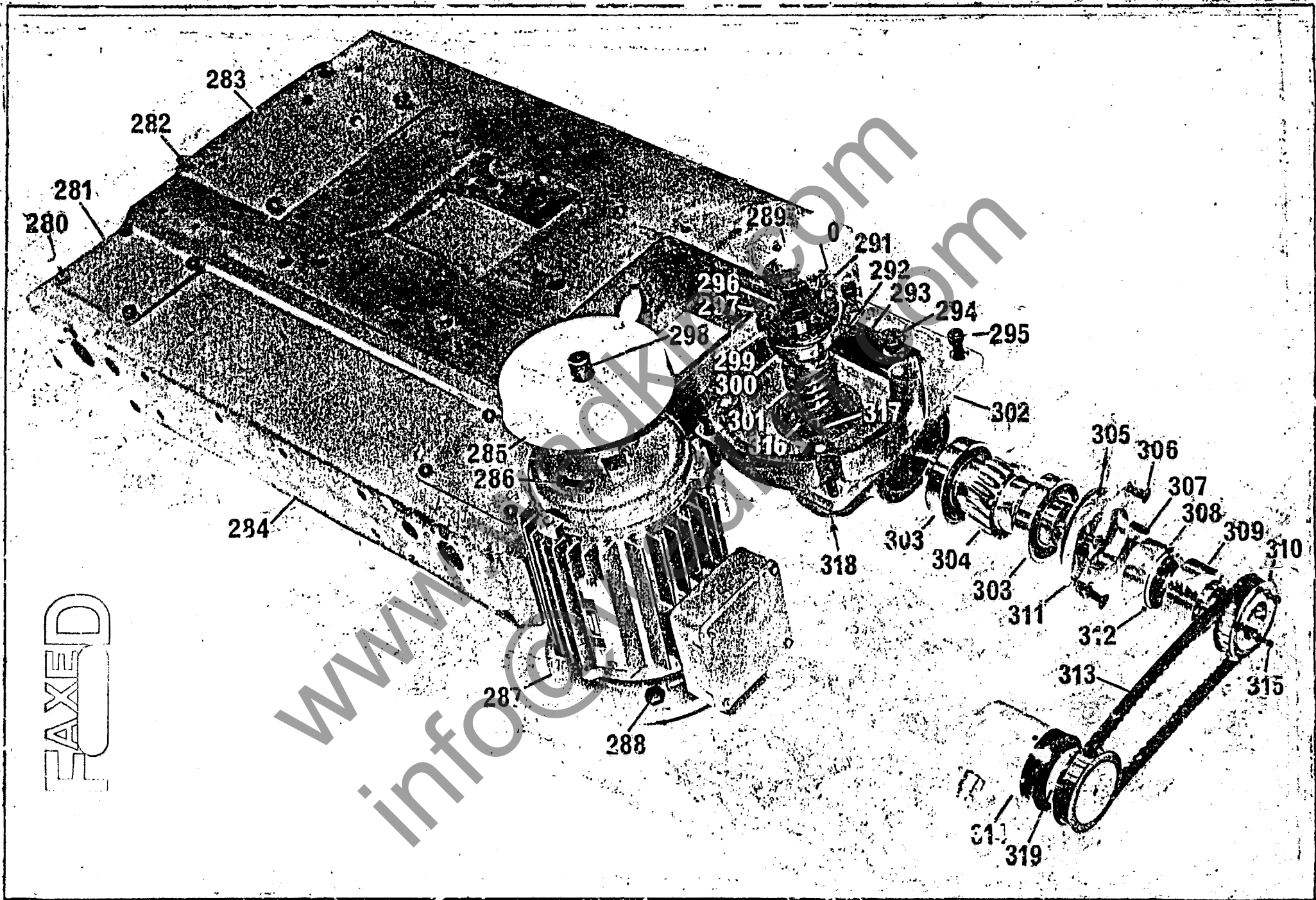

SADDLE ASSEMBLY, UNDERSIDE VIEW.

Ref. No.	Part No.	No. Off	Description
320		4	M16 x 30 long socket grubscrew.
321	1079/181- <i>DP1504</i>		Gib strip.
322	1079/355- <i>DP3004</i>		Adjustable bar for saddle gib strip.
323	1079/308- <i>DP2652</i>		Saddle gib strip.
324			4 mm dia pneumatic tubing (as required).
325	No. 114818	1	Seven way single junction.
326	K05-25-209	12	M10 x 25 Long socket capscrew.
327	1079/276- <i>DP25451</i>		Adjustable saddle.
328		16	M5 x 15 long cheese head screw.
329	1079/1353- <i>DP1324</i>		Bed wiper.
330	1079/1926	2	Top gib wiper - <i>DP1727</i>
331	1079/1352	2	Gib wiper. - <i>DP 1283</i>
332	1079/1927	2	Gib wiper. - <i>DP1734</i>

www.wadkin.com
 info@wadkin.com

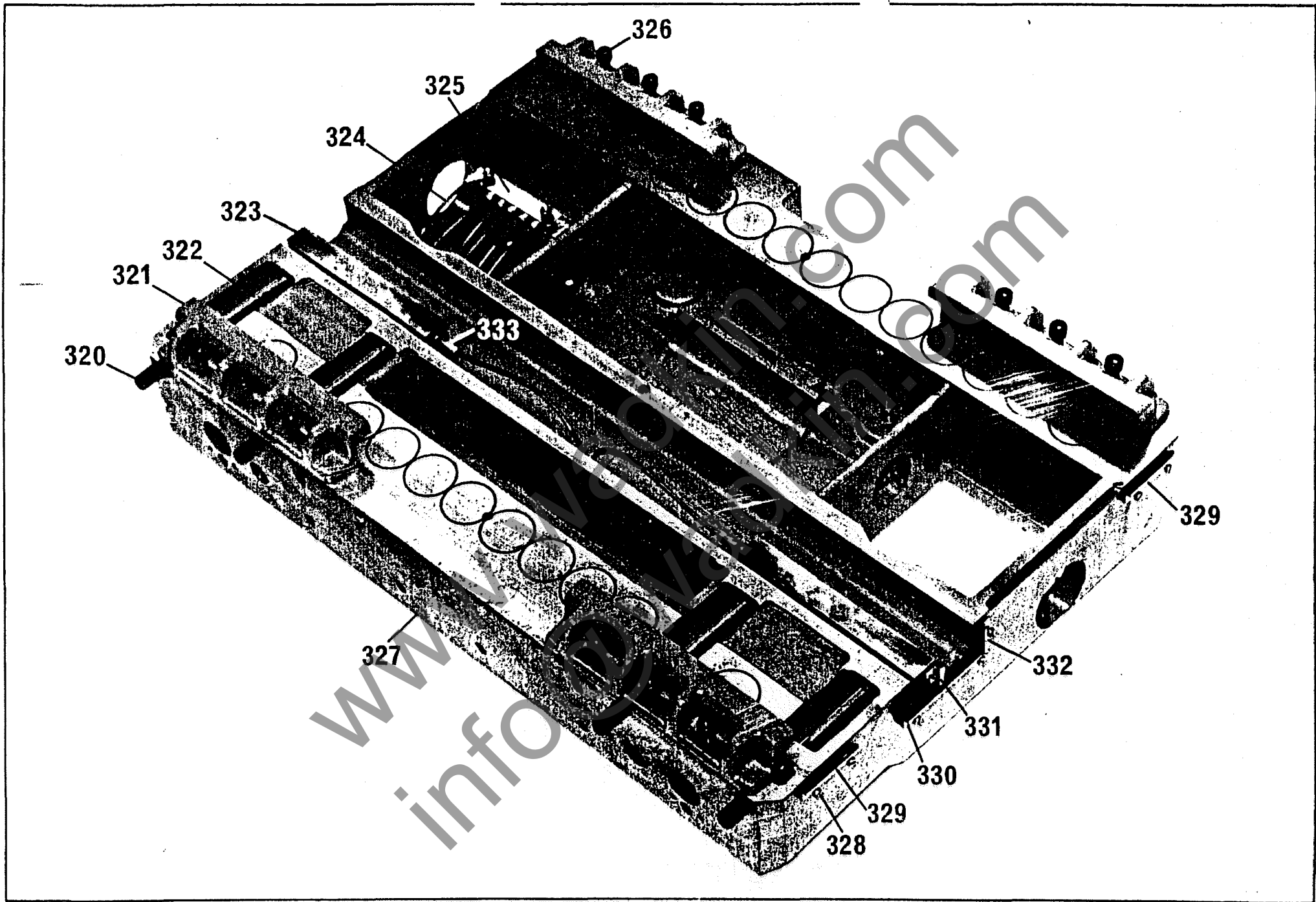

"A" TYPE HEAD SLIDE ASSEMBLY

Ref. No.	Part No.	No. Off	Description
340		1	"A" type motor (see motor plate when ordering)
341		4	3/8 whit aerotight nut
342		4	3/8 washer
343	1079/886	1	Right hand pivot pin
	1079/897	1	Left hand pivot pin
344		1	1/4" wide x 1/2" long feather key
345		6	5/16" whit x 1.1/4" long socket capscrew
346		2	3/8" whit x 1.1/2" long hexagon head bolt
347	1079/673	1	Wormwheel
348	1079/1013	1	Adjustable stop bolt for head
349		2	8mm dia x 32 long hardened ground dowel
350	1079/672	1	Pivot mounting for motor
351	1079/1014	1	Fixed stop bolt for head
352		1	M6 x 16 long socket grubscrew
353		2	6mm dia x 20 long hardened ground dowel
354	1079/1012	1	Left hand bracket for head stop
	1079/1213	1	Right hand bracket for head stop
355		1	M5 x 20 long socket grubscrew
356		1	M5 x 5 long socket grubscrew
357		2	M5 x 15 long button head socket screw
358	WE 613	1	Left hand "A" type interslide
	WE 614	1	Right hand "A" type interslide
359	1079/307	1	Gib strip
360	WE 653	1	Left hand brass wormwheel
	WE 663	1	Right hand brass wormwheel
361	1079/878	1	Washer
362	WE 674	1	Cover for slide
363		4	1/4" whit x 1/2" long countersunk socket screw
364		2	12mm washer
365		4	1/2" whit lock nut
366	1079/1636	1	Traverse nut
367		2	M8 x 8 long socket grubscrew
		2	Lead air pellet
368	1079/294	1	Locking collar
369	1079/1807	1	"A" traverse screw
370	GPZ 8104	2	Thrust bearing
371		2	Bristol locking handle M10 tap
372		1	M5 x 28 long groverlock dowel
373	WE 742	2	Canting or locking screw
374	1079/294	2	Thrust collar for traverse screw
375		2	5mm dia x 28 long groverlock spring dowel
376	1079/1804	1	Collar
377			Horizontal counter (Rotation 4)
378		2	M12 x 20 long socket grubscrew
379		1	M10 x 45 long stud
380	1079/90	1	Left hand backslide
	1079/70	1	Right hand backslide
381	1079/306	1	Gib strip
382		2	M12 x 25 long socket grubscrew
383		1	M8 x 20 long button head socket screw
384	EM/106	1	Washer for backslide
385		1	5/16" whit x 5/8" long countersunk socket screw

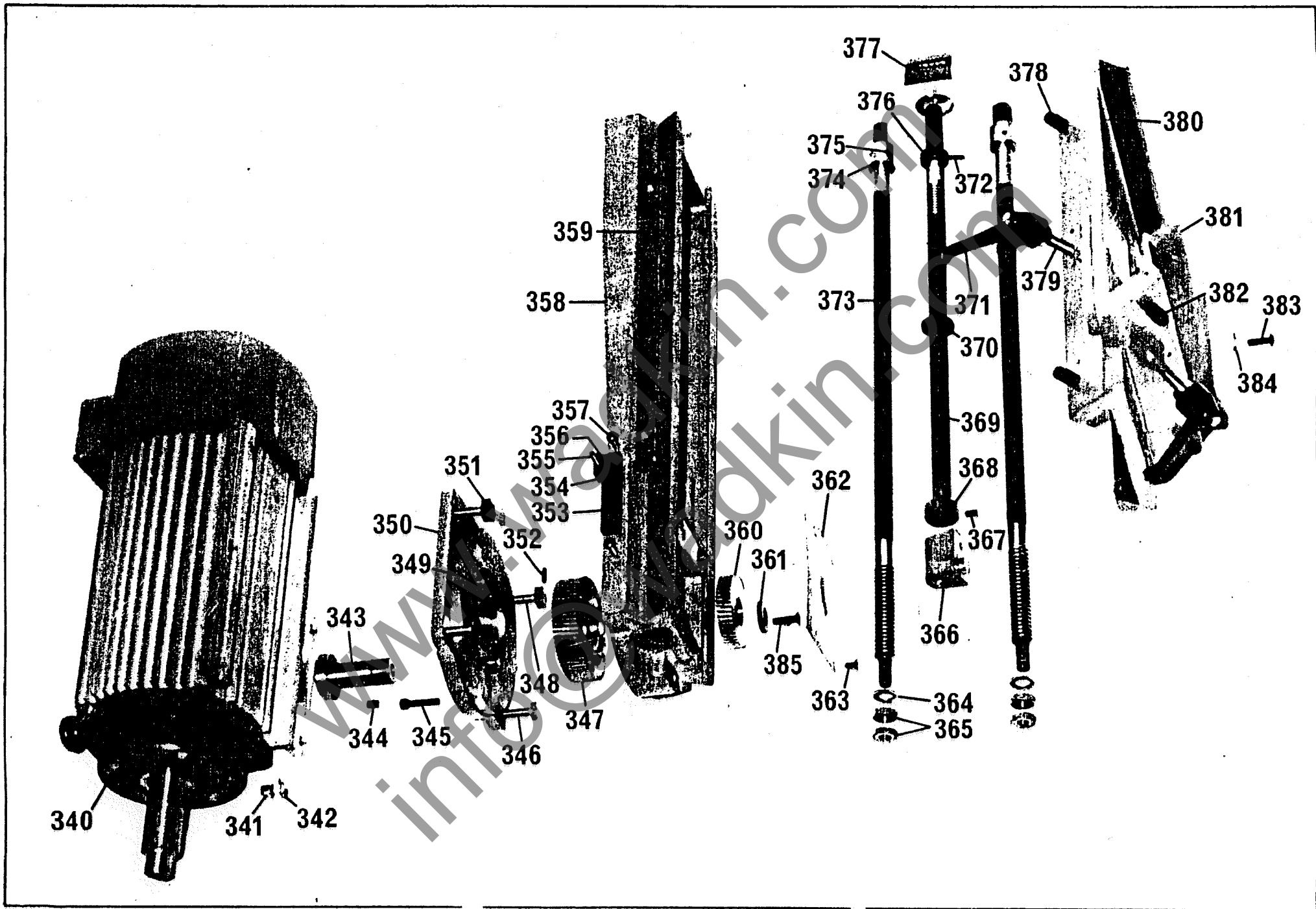

S9 JUMP SCORER ASSEMBLY.

Ref. No.	Part No.	No. Off	Description
400	WN 2111	2	Retaining collar for scoring saw flange
401	WN 2112	2	Flange for scoring saw.
402		1	Motor (see motor plate when ordering).
403	1079/1493	2	Scorer slide bar.
404		2	M12 nut.
405		2	M12 x 100 long hexagon head bolt.
406		2	M10 x 35 long socket capscrew.
407		2	M10 x 45 long stud.
408		4	3/8" whit x 1" long socket capscrew
409	1079/1887	1	Motor mounting bracket.
410	1079/840	1	Collar for lateral adjustment screw.
411		1	4 mm dia x 22 long groverlock dowel.
412	1079/801	1	Lateral adjustment screw.
413	1079/732	1	Nut for jump head.
414		2	M8 x 35 long socket capscrew.
415	KH 2540	4	Ball bushing.
416		4	25 1/D x 35 O/D x 4mm thick oil seal.
417		1	Solenoid/Spring valve 5/2 (1/4"BSP) 03-6011-50-110 with manual over-ride.
418	1079/1941	2	Solenoid mounting bracket.
419		1	Double acting cushioned cylinder 50 mm bore. 80 mm stroke No. 62-360-55-0080.
420		2	M10 x 30 long socket capscrew.
421	1079/1888	1	Scorer body.
422		2	8 mm dia x 38 long hardened ground dowel.
423	1079/1494	1	Scorer carriage.
424	1079/841	1	Cross slide.
425		2	M6 x 90° grease nipple.
426	1079/1072	2	Brass bot.
427	1079/694	1	Gib strip.
428		3	M8 x 25 long socket capscrew.
429		3	M8 x 25 long socket grubscrew.
430		3	M8 locknut.
431		4	M8 x 35 long socket capscrew.
432		2	M8 x 25 long socket capscrew.
433		1	Rod end locknut No. 62-351-61-0000.
434		6	M8 x 30 long socket capscrew.
435	1079/604	1	Jump scorer tie bracket.
436		2	M10 tap Bristol locking handle.

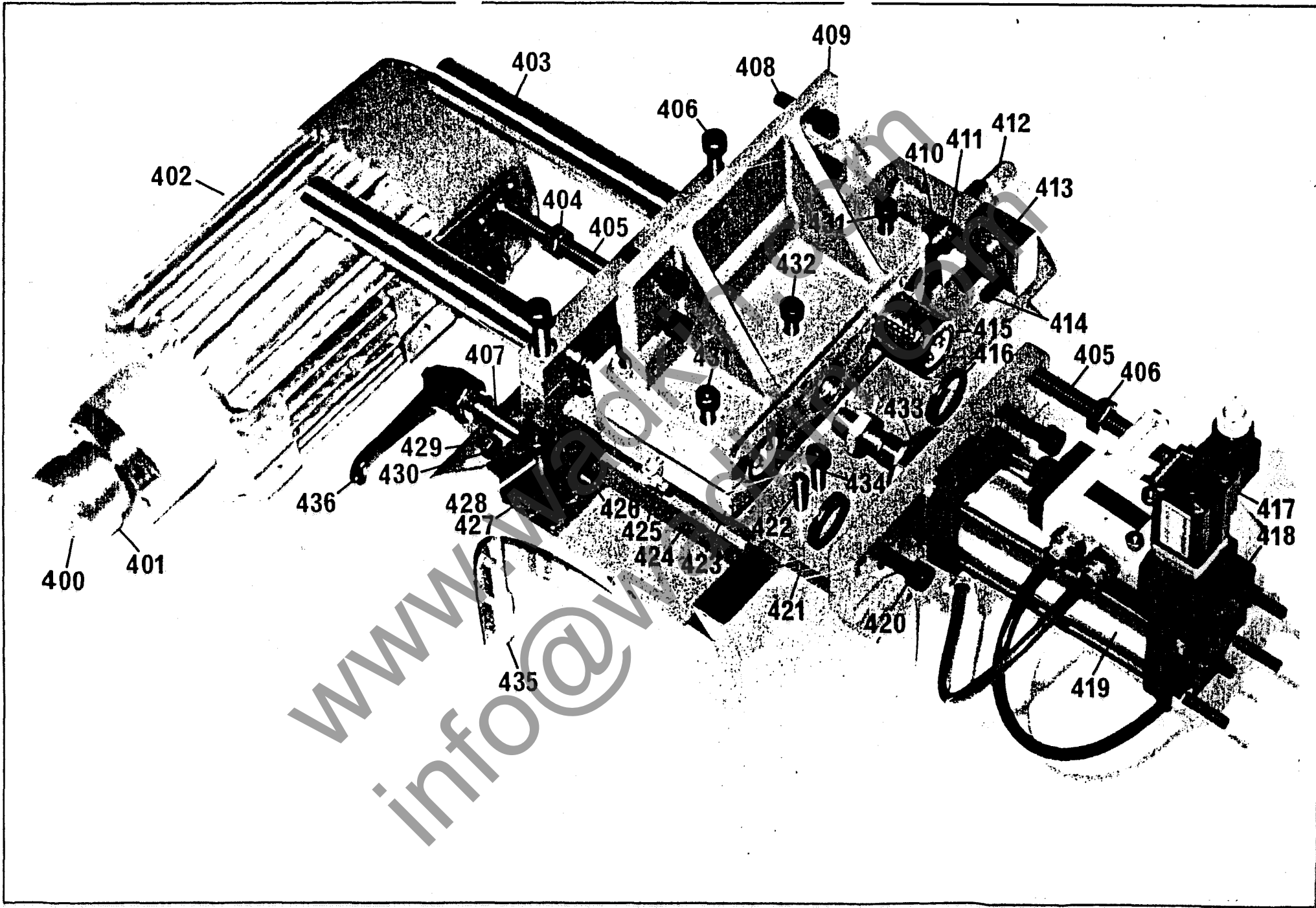

BACKSHAFT DRIVE ASSEMBLY.

Ref. No.	Part No.	No. Off	Description
450	1079/260	1	Feed gearbox tie piece (RH).
451	1079/611	1	Variable pulley adjusting screw.
452	1079/613	1	Pointer.
		2	M6 x 6 long socket grubscrew and lead pellet.
453	1079/625	1	Feed speed plate.
	1079/630	1	Block for feed speed plate.
		2	M6 x 25 Long socket capscrew for block.
		2	Z4 self tapping screw for feed speed plate.
454	1079/1364	1	Variable pulley thrust plate.
455		1	M10 tap Bristol locking handle.
		1	M10 x 45 Long stud.
		1	8 mm dia x 65 long brass bolt.
456	1079/1365	3	Stud for pressure plate.
		6	M10 locknut.
		3	10 mm spring washer.
457		1	FC-275-50 MA mechanical adjusted pulley, 32 mm bore.
458	41-553-04	1	Croft worm reduction gear unit.
459		4	M16 x 60 long hexagon head bolt.
		4	M16 nut.
		8	16 mm washer.
		4	16 mm spring washer.
460	1079/261	1	Feed gearbox housing.
461		1	Schmersal TYPE-TQ441-01/01-380v trip switch.
462	1079/1010	1	Angle bracket for trip wire.
463		4	M16 x 60 long hexagon head bolt.
		8	16 mm washer.
		4	M16 nut.
464		2	M12 x 60 long hexagon head bolt.
		2	M12 nut.
465		1	Supaflex belt 50/1400.
466		1	FC-275-50 SA spring adjusted pulley, 38 mm bore.
467		2	M8 x 145 long securing screw with 90° grease nipple.
468	1079/760	2	Feed motor adjusting plate.
469		8	M12 nut.
		8	12 mm washer.
		8	12 mm spring washer.
470		1	Feed motor (see motor plate when ordering).
471			8mm dia pneumatic tubing (state length required).
472			Metaflex 3 x 1 mm cable (state length required).

